

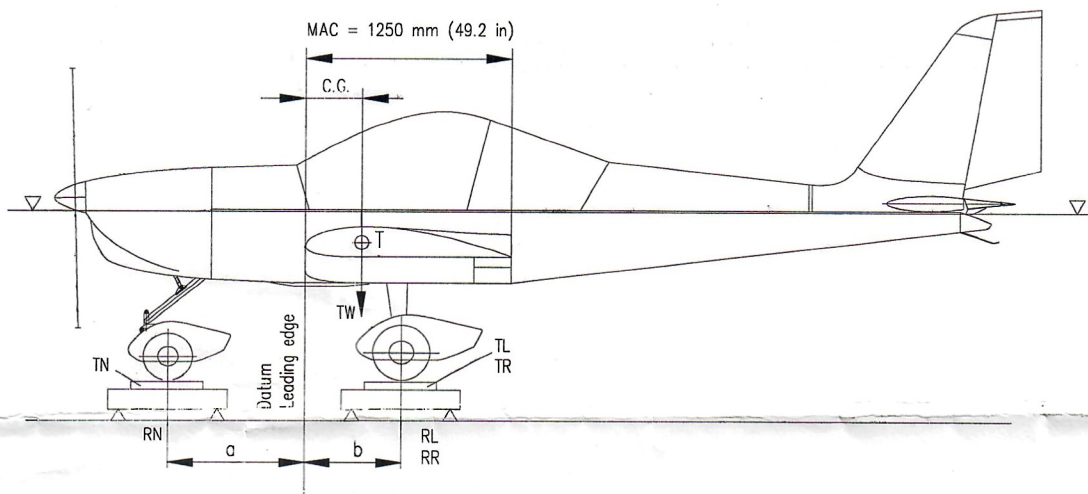

WEIGHT AND BALANCE RECORD of SportStar^{plus} Aircraft

Serial Number :	2007 0816	Registration :	N816EV
Order :	640090		
Configuration :	Engine R912 ULS, Alternator SD20, Oil Thermostat, Engine Analog Instruments Mitchell, Fuel Pressure Gauge Mitchell, Fuel Gauge Mitchell-2pcs, Propeller WOODCOMP Klassic 170/3/R, Airspeed Indicator, Altimeter, Vertical Speed Indicator, Compass, Hourmeter HOBBS, Horizon ADI TruTrak, Outside Air Thermometer, Voltmeter, Autopilot TruTrack DigiFlight II, Preinstallation GPS396MAP, Transceiver SL40, Transponder GTX327, Altitude Encoder ACK A-30, WHELEN A600 Beacons, WHELEN A715 Landing Light, WHELEN Swivel Cabin Light, Instruments Lighting, ELT AK-450, Heating, Dual Front Section Canopy Blowing, Vent Holes Dual Front+L+R, Alfa Romeo Vent Flap, Dual brake system with brake pump on each pedal, Parking Brake, Adjustable Pedals, Tyres Cheng-Shin 15x6-6,00, Wheel Fairings, Baggage Compartment Upholstery, Instrument Board Cover Upholstery, Luggage Rack, Padded Shoulder Guards, Sun Shades, Sun Shade KOGER, Oil Check Cover, Wide Canopy Brown, Dual Electric Trim System, Electrical Fuel Pump ROTAX, Integral Fuel Tanks 2x15.85 US.gal.		



Weighing Point	Scale Reading R _i [lbs] or [kg]	Tare T _i [lbs] or [kg]	Net Weight NW _i = R _i -T _i [lbs] or [kg]
Nose wheel	R _{nose} = 162,04	T _{nose} = 0,44	NW _{nose} = 161,60
Left wheel	R _{left} = 300,71	T _{left} = 0,44	NW _{left} = 300,27
Right wheel	R _{right} = 290,57	T _{right} = 0,44	NW _{right} = 290,13
Distance Suports	a = 30,59 [in] or [mm]		
	b = 22,24 [in] or [mm]		
Total Weight [lbs] or [kg]			
TW = NW _{nose} + NW _{left} + NW _{right}			TW = 752,00
C.G. Position from Datum (Leading edge) [in] or [mm]			
$C.G. = \frac{(NW_L + NW_R) \times b - NW_N \times a}{TW}$			C.G. = 10,89
C.G. Position [% MAC]			
$C.G. = \frac{C.G. \text{ [in] or [mm]}}{MAC \text{ [in] or [mm]}} \times 100$			22,12
Permitted C.G. range of empty Airplane (standard equipment) : 20 ± 2 % MAC			

EVEKTOR - AEROTECHNIK s.r.o.

Carried out by :	Libor Ševčík	Signature :	 Letecká čp. 1394 PSČ 836 04, Kufřovice CZECH REPUBLIC
Date :	01.02.2007		